

HOFFER

Perfecting Measurement™



Двухпроводной процессорный трансмиссер Cat 1

Технические характеристики

По вопросам продаж и поддержки обращайтесь:

Архангельск +7 (8182) 45-71-35	Калининград +7 (4012) 72-21-36	Новороссийск +7 (8617) 30-82-64	Сочи +7 (862) 279-22-65
Астана +7 (7172) 69-68-15	Калуга +7 (4842) 33-35-03	Новосибирск +7 (383) 235-95-48	Ставрополь +7 (8652) 57-76-63
Астрахань +7 (8512) 99-46-80	Кемерово +7 (3842) 21-56-70	Омск +7 (381) 299-16-70	Сургут +7 (3462) 77-96-35
Барнаул +7 (3852) 37-96-76	Киров +7 (8332) 20-58-70	Орел +7 (4862) 22-23-86	Сызрань +7 (8464) 33-50-64
Белгород +7 (4722) 20-58-80	Краснодар +7 (861) 238-86-59	Оренбург +7 (3532) 48-64-35	Сыктывкар +7 (8212) 28-83-02
Брянск +7 (4832) 32-17-25	Красноярск +7 (391) 989-82-67	Пенза +7 (8412) 23-52-98	Тверь +7 (4822) 39-50-56
Владивосток +7 (4232) 49-26-85	Курск +7 (4712) 23-80-45	Первоуральск +7 (3439) 26-01-18	Томск +7 (3822) 48-95-05
Владимир +7 (4922) 49-51-33	Липецк +7 (4742) 20-01-75	Пермь +7 (342) 233-81-65	Тула +7 (4872) 44-05-30
Волгоград +7 (8442) 45-94-42	Магнитогорск +7 (3519) 51-02-81	Ростов-на-Дону +7 (863) 309-14-65	Тюмень +7 (3452) 56-94-75
Воронеж +7 (4732) 12-26-70	Москва +7 (499) 404-24-72	Рязань +7 (4912) 77-61-95	Ульяновск +7 (8422) 42-51-95
Екатеринбург +7 (343) 302-14-75	Мурманск +7 (8152) 65-52-70	Самара +7 (846) 219-28-25	Уфа +7 (347) 258-82-65
Иваново +7 (4932) 70-02-95	Наб.Челны +7 (8552) 91-01-32	Санкт-Петербург +7 (812) 660-57-09	Хабаровск +7 (421) 292-95-69
Ижевск +7 (3412) 20-90-75	Ниж.Новгород +7 (831) 200-34-65	Саранск +7 (8342) 22-95-16	Чебоксары +7 (8352) 28-50-89
Иркутск +7 (3952) 56-24-09	Нижневартовск +7 (3466) 48-22-23	Саратов +7 (845) 239-86-35	Челябинск +7 (351) 277-89-65
Йошкар-Ола +7 (8362) 38-66-61	Нижнекамск +7 (8555) 24-47-85	Смоленск +7 (4812) 51-55-32	Череповец +7 (8202) 49-07-18
Казань +7 (843) 207-19-05			Ярославль +7 (4852) 67-02-35

сайт: \ cZyf.pro-solution.ru | эл. почта: \ fz@pro-solution.ru
телефон: 8 800 511 88 70

FLOWMETERS BY HOFFER

Perfecting Measurement™



CAT1

SERIES

Conditioners-Amplifiers-Transmitters

Product Bulletin CAT1-001G

TECHNICAL DATA SHEET

OUTSTANDING FEATURES

- ◆ Loop powered 4-20mA.
- ◆ Optional flowmeter linearization.
- ◆ Factory configured when purchased with a Hoffer flowmeter.
- ◆ Several enclosure options.
- ◆ CE Compliant.
- ◆ Windows® Configuration Software.

SPECIFICATIONS

Input Signal Type:	Magnetic pickup
Input Frequency Range:	0.2 Hz to 4 KHz
Signal Level:	10 mV rms to 30 Vdc
Power Supply:	Loop Power 10-30 Vdc Reverse polarity protected
Loop Burden Voltage:	8.5 V
Analog Output:	4-20mA
Analog Output Response Time:	1/8 sec. (Limited by frequency and MST settings)
Load Resistance:	Max 650 Ohms at 24 Vdc
Accuracy:	±0.02% of full scale
Temperature Drift:	40 ppm/deg. C
Communications:	RS232 port for configuration and diagnostics
Operating Temperature:	-40° to +185°F (-40° to +85°C)
Humidity:	0-90% Non-Condensing
Enclosure:	Extruded Aluminum DIN Rail Mount Explosion-Proof
Regulatory:	CE Compliant

Up to 12 point linearization.

Windows® Configuration Software for Device configuration, diagnostics and monitoring.



PRODUCT DESCRIPTION

The CAT1 is a microprocessor controlled 2-wire 4-20mA transmitter. The CAT1 converts a low level, frequency signal from a flowmeter sensor into an analog 4-20mA output. The output is proportional to the flow rate.

INSTALLATION WIRING

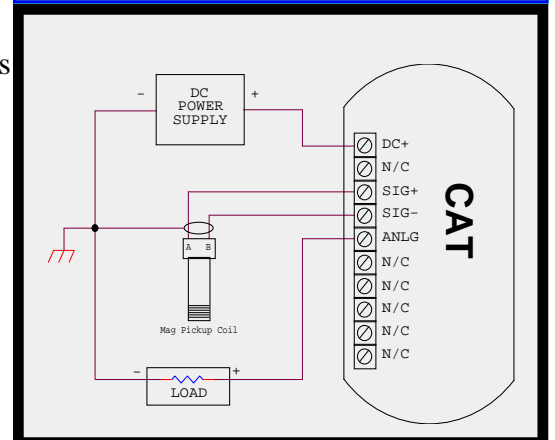

ENCLOSURE OPTIONS

General Purpose Enclosure

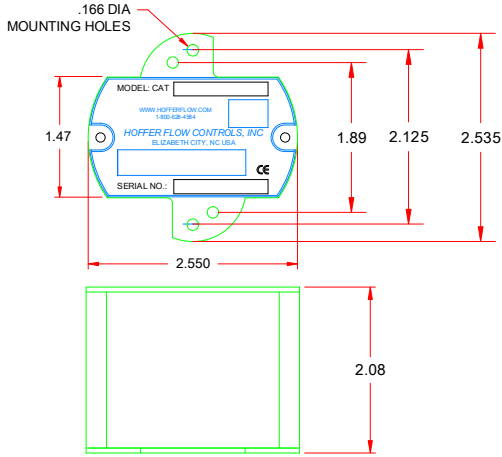

DIN Style Enclosure

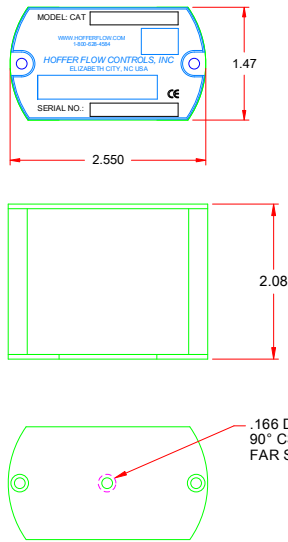

Exd System Ratings for E3 and E6 Enclosures: (Pending)

CSA/FM:

CLASS I, DIV.1, GR.BCD, CLASS II, DIV.1, GR. EFG, CLASS III, TYPE 4X, IP66

CLASS I ZONE 1 AEx d IIB+H2, IP66

ATEX/IECEX:

II 2 G Ex d IIB+H2, T1-T6 Gb; IP66

T1-T5: -40°C ≤ T_a ≤ 85°C; T6: -40°C ≤ T_a ≤ 80°C

ORDERING INFORMATION

Model CAT1- () - () - () - ()

ENCLOSURE STYLE

- 1 GENERAL PURPOSE ENCLOSURE
- D 2" LONG DIN RAIL MOUNT SINGLE UNIT. UP TO 20 CAN BE MOUNTED ON A SINGLE RAIL.
- E3(*) † EXPLOSION-PROOF ENCLOSURE
- E6(*) † STAINLESS-STEEL EXPLOSION-PROOF ENCLOSURE

* INSERT "M" FOR M20 THREAD. M20 THREAD NOT AVAILABLE IN CANADA FOR STYLE E6 ENCLOSURES.

† FOR CERTIFIED SYSTEM SPECIFY "CFX" OPTION WHEN MOUNTED ON

LINEARIZED ANALOG OUTPUT

- (7) 4 TO 20 MA UP TO 20 POINTS. ACCURACY +/- 0.02% OF FULL SCALE.

INPUT POWER

- (D) 8 TO 24 VDC LOOP POWERED

SPECIAL FEATURES

- (CE) MARK REQUIRED FOR EUROPE
- (SP) ANY SPECIAL FEATURES THAT ARE NOT COVERED IN THE MODEL NUMBER, USE A WRITTEN DESCRIPTION OF THE -SP.
- (CFX) 6.75" LONG RISER AND UNION FOR EXPLOSION-PROOF SYSTEM CERTIFIED ENCLOSURES MOUNTED ON TURBINE. USED WITH "X" RISER TURBINE OPTION. NOTE: IF PROCESS TEMP IS < -40°C OR > 85°C, EX-PROOF ENCLOSURE MUST BE MOUNTED REMOTELY.

NOTES:

1. IF ENCLOSURE IS MOUNTED ON TURBINE FLOWMETER, RISER MUST BE SPECIFIED ON METER.
2. INPUTS: ACCEPTS MAGNETIC COIL ONLY.
3. IF THE CAT IS SHIPPED UNCALIBRATED OR IS RECALIBRATED IN THE FIELD, THE WINDOWS BASED SETUP KIT MUST BE PURCHASED. CONTACT FACTORY.

E3 Explosion-Proof Enclosure

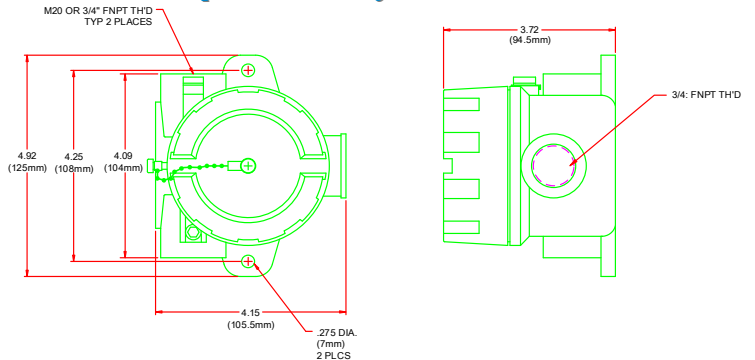

E6 Explosion-Proof Enclosure

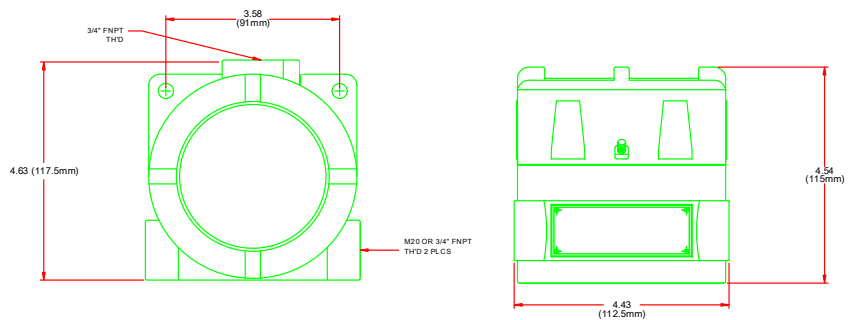

The quality system covering the design, manufacture and testing of our products is certified to International Standard ISO 9001.



По вопросам продаж и поддержки обращайтесь:

Архангельск +7 (8182) 45-71-35	Калининград +7 (4012) 72-21-36	Новороссийск +7 (8617) 30-82-64	Сочи +7 (862) 279-22-65
Астана +7 (7172) 69-68-15	Калуга +7 (4842) 33-35-03	Новосибирск +7 (383) 235-95-48	Ставрополь +7 (8652) 57-76-63
Астрахань +7 (8512) 99-46-80	Кемерово +7 (3842) 21-56-70	Омск +7 (381) 299-16-70	Сургут +7 (3462) 77-96-35
Барнаул +7 (3852) 37-96-76	Киров +7 (8332) 20-58-70	Орел +7 (4862) 22-23-86	Сызрань +7 (8464) 33-50-64
Белгород +7 (4722) 20-58-80	Краснодар +7 (861) 238-86-59	Оренбург +7 (3532) 48-64-35	Сыктывкар +7 (8212) 28-83-02
Брянск +7 (4832) 32-17-25	Красноярск +7 (391) 989-82-67	Пенза +7 (8412) 23-52-98	Тверь +7 (4822) 39-50-56
Владивосток +7 (4232) 49-26-85	Курск +7 (4712) 23-80-45	Первоуральск +7 (3439) 26-01-18	Томск +7 (3822) 48-95-05
Владимир +7 (4922) 49-51-33	Липецк +7 (4742) 20-01-75	Пермь +7 (342) 233-81-65	Тула +7 (4872) 44-05-30
Волгоград +7 (8442) 45-94-42	Магнитогорск +7 (3519) 51-02-81	Ростов-на-Дону +7 (863) 309-14-65	Тюмень +7 (3452) 56-94-75
Воронеж +7 (4732) 12-26-70	Москва +7 (499) 404-24-72	Рязань +7 (4912) 77-61-95	Ульяновск +7 (8422) 42-51-95
Екатеринбург +7 (343) 302-14-75	Мурманск +7 (8152) 65-52-70	Самара +7 (846) 219-28-25	Уфа +7 (347) 258-82-65
Иваново +7 (4932) 70-02-95	Наб.Челны +7 (8552) 91-01-32	Санкт-Петербург +7 (812) 660-57-09	Хабаровск +7 (421) 292-95-69
Ижевск +7 (3412) 20-90-75	Ниж.Новгород +7 (831) 200-34-65	Саранск +7 (8342) 22-95-16	Чебоксары +7 (8352) 28-50-89
Иркутск +7 (3952) 56-24-09	Нижневартовск +7 (3466) 48-22-23	Саратов +7 (845) 239-86-35	Челябинск +7 (351) 277-89-65
Йошкар-Ола +7 (8362) 38-66-61	Нижнекамск +7 (8555) 24-47-85	Смоленск +7 (4812) 51-55-32	Череповец +7 (8202) 49-07-18
Казань +7 (843) 207-19-05			Ярославль +7 (4852) 67-02-35

сайт: \ cZyf.pro-solution.ru | эл. почта: \ fz@pro-solution.ru |
телефон: 8 800 511 88 70



The specifications contained herein are subject to change without notice and any user of said specifications should verify from the manufacturer that the specifications are currently in effect. Otherwise, the manufacturer assumes no responsibility for the use of specifications which may have been changed and are no longer in effect.

The quality system covering the design, manufacture and testing of our products is certified to International Standard ISO 9001.

