

HOFFER

Perfecting Measurement™



Запасные части и комплектующие турбинных расходомеров серии НО

Технические характеристики

По вопросам продаж и поддержки обращайтесь:

Архангельск +7 (8182) 45-71-35	Калининград +7 (4012) 72-21-36	Новороссийск +7 (8617) 30-82-64	Сочи +7 (862) 279-22-65
Астана +7 (7172) 69-68-15	Калуга +7 (4842) 33-35-03	Новосибирск +7 (383) 235-95-48	Ставрополь +7 (8652) 57-76-63
Астрахань +7 (8512) 99-46-80	Кемерово +7 (3842) 21-56-70	Омск +7 (381) 299-16-70	Сургут +7 (3462) 77-96-35
Барнаул +7 (3852) 37-96-76	Киров +7 (8332) 20-58-70	Орел +7 (4862) 22-23-86	Сызрань +7 (8464) 33-50-64
Белгород +7 (4722) 20-58-80	Краснодар +7 (861) 238-86-59	Оренбург +7 (3532) 48-64-35	Сыктывкар +7 (8212) 28-83-02
Брянск +7 (4832) 32-17-25	Красноярск +7 (391) 989-82-67	Пенза +7 (8412) 23-52-98	Тверь +7 (4822) 39-50-56
Владивосток +7 (4232) 49-26-85	Курск +7 (4712) 23-80-45	Первоуральск +7 (3439) 26-01-18	Томск +7 (3822) 48-95-05
Владимир +7 (4922) 49-51-33	Липецк +7 (4742) 20-01-75	Пермь +7 (342) 233-81-65	Тула +7 (4872) 44-05-30
Волгоград +7 (8442) 45-94-42	Магнитогорск +7 (3519) 51-02-81	Ростов-на-Дону +7 (863) 309-14-65	Тюмень +7 (3452) 56-94-75
Воронеж +7 (4732) 12-26-70	Москва +7 (499) 404-24-72	Рязань +7 (4912) 77-61-95	Ульяновск +7 (8422) 42-51-95
Екатеринбург +7 (343) 302-14-75	Мурманск +7 (8152) 65-52-70	Самара +7 (846) 219-28-25	Уфа +7 (347) 258-82-65
Иваново +7 (4932) 70-02-95	Наб.Челны +7 (8552) 91-01-32	Санкт-Петербург +7 (812) 660-57-09	Хабаровск +7 (421) 292-95-69
Ижевск +7 (3412) 20-90-75	Ниж.Новгород +7 (831) 200-34-65	Саранск +7 (8342) 22-95-16	Чебоксары +7 (8352) 28-50-89
Иркутск +7 (3952) 56-24-09	Нижневартовск +7 (3466) 48-22-23	Саратов +7 (845) 239-86-35	Челябинск +7 (351) 277-89-65
Йошкар-Ола +7 (8362) 38-66-61	Нижнекамск +7 (8555) 24-47-85	Смоленск +7 (4812) 51-55-32	Череповец +7 (8202) 49-07-18
Казань +7 (843) 207-19-05			Ярославль +7 (4852) 67-02-35

сайт: \ cZyf.pro-solution.ru | эл. почта: \ fz@pro-solution.ru
телефон: 8 800 511 88 70

TECHNICAL DATA SHEET

Replacement Parts and Calibrated Internals

Hoffer turbine flowmeters are easily repaired in the field with a minimum number of tools. A spare complete set of calibrated internals can provide nearly continuous operation of a flowmeter that has been damaged or needs to be recalibrated, and are available in all sizes. Calibrated kits are supplied with a NIST traceable calibration data sheet. For detailed technical information, refer to the "Hoffer Engineering Guide". When ordering replacement or spare parts, please provide the Hoffer model number or serial number of the original unit.

Component Exploded View

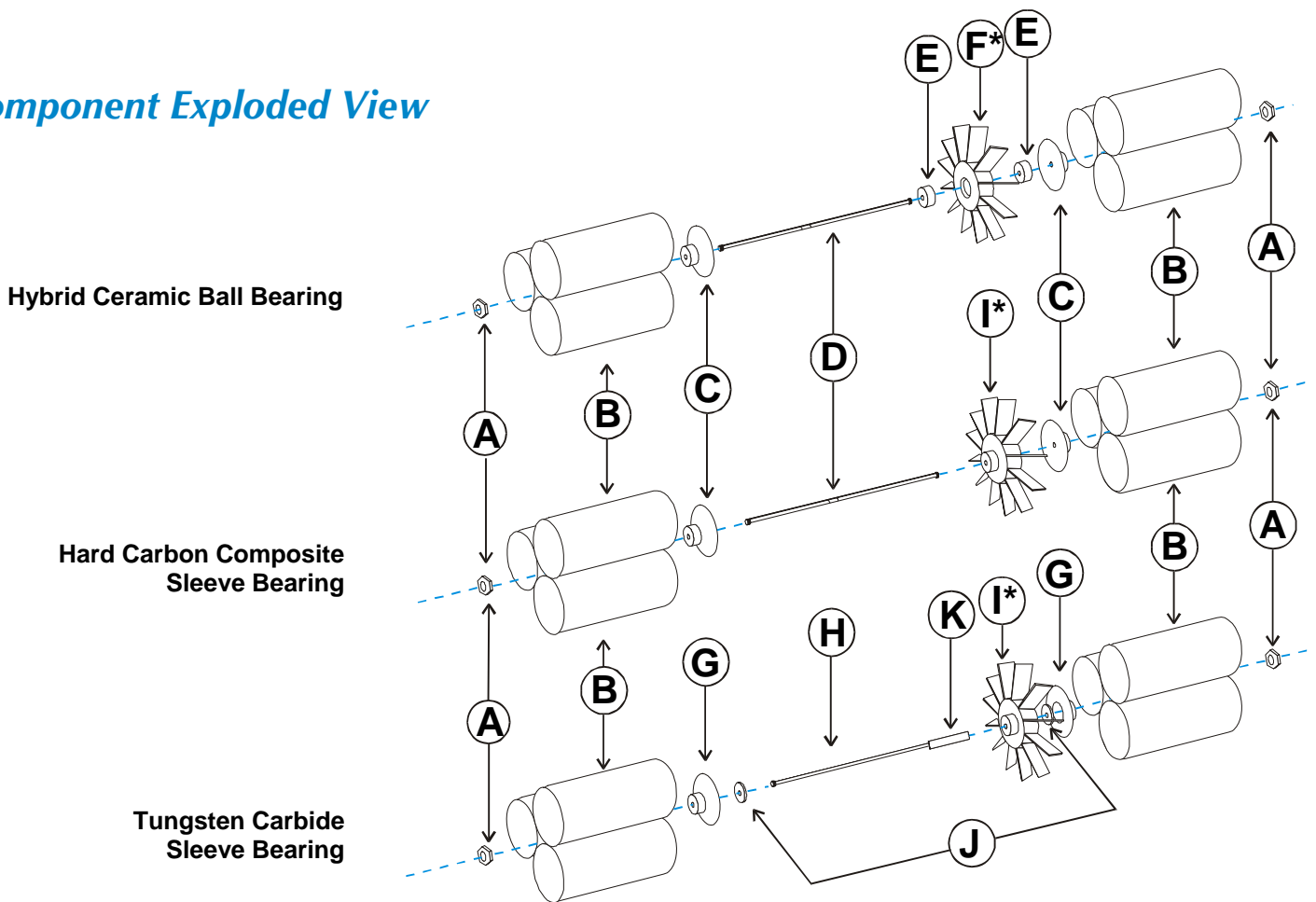

* Number of blades, blade angle and length of blades vary with application and meter size.

KEY

- | | |
|-------------------------------|--|
| A—Lock Nut | G—Cone |
| B—Flow Straightener (hangers) | H—Shaft |
| C—Cone | I—Bushing & Rotor (Press Fit at Factory) |
| D—Shaft | J—T/C Washers |
| E—Bearings | K—Journal |
| F—Rotor | |

HO Series Calibrated Spare or Replacement Internal Kits

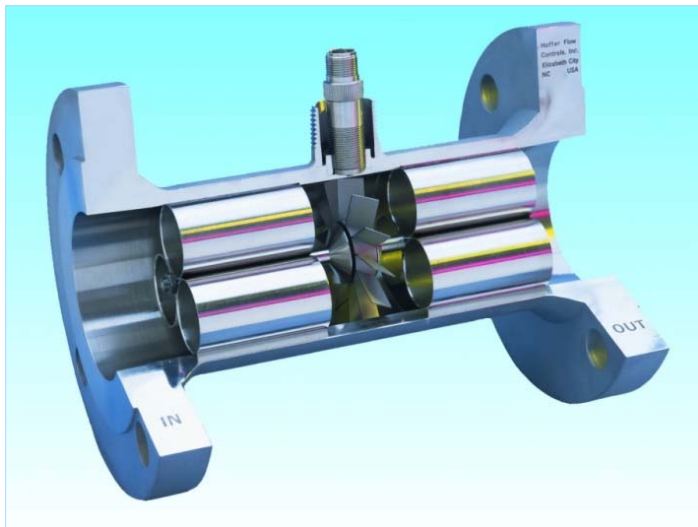

Note : Calibrated kits are supplied with calibration data sheet.

MODEL HO	-	-	-	-	-	INTERNALS
Flowmeter Size						
Minimum Flow Range						
Maximum Flow Range						
Bearing Type						
CB	- Ceramic Hybrid self-lubricating ball bearings.					
T	- Tungsten Carbide.					
TFE	- Teflon.					
C	- Hard Carbon Composite.					

Spare and Replacement Pickup Coils

Part No.	Description or Service	Temperature Rating
MC3PAE	RF Coil 1/2" MNPT & 3" Leads	-325° to +325°F
MC3PA	RF Coil All HO Series	-325° to +325°F
PC13-110G	Cryogenic HO 1 & Up	-450° to +450°F
PC13-74G	WECO HO 2x2 & HO 3x3 Liquid & Navy	-450° to +450°F
PC13-74S	HO Series HO1 & UP & Mini-Flows	-450° to +450°F
PC24-45G	HO1/4 thru HO3/4 Cryogenic, Trident & SY100	-450° to +450°F
PC24-45S	HO1/4 thru HO 3/4 & HO1 & Larger Gas	-450° to +450°F
PC24-45EX	HO1/4 thru HO 3/4 & HO1 & Larger Gas with 1/2" MNPT & 3" Leads	-450° to +450°F
PC28-13G	High Temp High Drag	-450° to +850°F
PC3-24G	Reluctance Center Mag for All Teflon	+35° to +120°F
PC24-92G	Hydrogen Vacuum Jacket	-450° to +450°F
PC28-14G	High Temp Low Drag	-450° to +850°F
PC3-24EX	Reluctance Teflon Series with 1/2" MNPT & 3" Leads	+35° to +120°F
MC2PAHT	High Temp RF with 3' Leads	-450° to +450°F

Part No.	Description or Service	Temperature Rating
MC2PA	High Temp 2 Pin RF	-150° to +330°F
PC13-108G	Cryogenic 1" & Larger	-450° to +450°F
PC24-113G	WECO HO2x1 & HO2x1½ Liquid and Gas	-450° to +450°F
PC13-74EX	Hi Drag with 1/2" MNPT & 3" Leads	-450° to +450°F
PC13-74S	Cryogenic 1" & Larger	-450° to +450°F
RF-4	WECO's All Sizes Requiring RF	-325° to +325°F
ISM-001	Intrinsic Mag Hi Drag 1" & Up & Mini-Flow Use	-97° to +207°F
PC24-123G	WECO HO2x2 & HO3x3 Gas	-450° to +450°F
ISM-003	Intrinsic Mag Low Drag 3/4" & Smaller Use	-97° to +207°F
ISM-006	Intrinsic Reluctance for All Teflon Use	+35° to +120°F
PC28-38G	Hi Temp/Hi Drag for WECO HO 2x1½ & HO2x1	-450° to +850°F
PC3-33G	Reluctance Teflon Hi Output	+35° to +120°F
HE01S	Hall Effect Coil for HOG	-40° to +302°F
M-L3/8X1.52	Lo-Co Coil	-50° to +250°F



The quality system covering the design, manufacture and testing of our products is certified to international Standard ISO 9001.



По вопросам продаж и поддержки обращайтесь:

Архангельск +7 (8182) 45-71-35	Калининград +7 (4012) 72-21-36	Новороссийск +7 (8617) 30-82-64	Сочи +7 (862) 279-22-65
Астана +7 (7172) 69-68-15	Калуга +7 (4842) 33-35-03	Новосибирск +7 (383) 235-95-48	Ставрополь +7 (8652) 57-76-63
Астрахань +7 (8512) 99-46-80	Кемерово +7 (3842) 21-56-70	Омск +7 (381) 299-16-70	Сургут +7 (3462) 77-96-35
Барнаул +7 (3852) 37-96-76	Киров +7 (8332) 20-58-70	Орел +7 (4862) 22-23-86	Сызрань +7 (8464) 33-50-64
Белгород +7 (4722) 20-58-80	Краснодар +7 (861) 238-86-59	Оренбург +7 (3532) 48-64-35	Сыктывкар +7 (8212) 28-83-02
Брянск +7 (4832) 32-17-25	Красноярск +7 (391) 989-82-67	Пенза +7 (8412) 23-52-98	Тверь +7 (4822) 39-50-56
Владивосток +7 (4232) 49-26-85	Курск +7 (4712) 23-80-45	Первоуральск +7 (3439) 26-01-18	Томск +7 (3822) 48-95-05
Владимир +7 (4922) 49-51-33	Липецк +7 (4742) 20-01-75	Пермь +7 (342) 233-81-65	Тула +7 (4872) 44-05-30
Волгоград +7 (8442) 45-94-42	Магнитогорск +7 (3519) 51-02-81	Ростов-на-Дону +7 (863) 309-14-65	Тюмень +7 (3452) 56-94-75
Воронеж +7 (4732) 12-26-70	Москва +7 (499) 404-24-72	Рязань +7 (4912) 77-61-95	Ульяновск +7 (8422) 42-51-95
Екатеринбург +7 (343) 302-14-75	Мурманск +7 (8152) 65-52-70	Самара +7 (846) 219-28-25	Уфа +7 (347) 258-82-65
Иваново +7 (4932) 70-02-95	Наб.Челны +7 (8552) 91-01-32	Санкт-Петербург +7 (812) 660-57-09	Хабаровск +7 (421) 292-95-69
Ижевск +7 (3412) 20-90-75	Ниж.Новгород +7 (831) 200-34-65	Саранск +7 (8342) 22-95-16	Чебоксары +7 (8352) 28-50-89
Иркутск +7 (3952) 56-24-09	Нижневартовск +7 (3466) 48-22-23	Саратов +7 (845) 239-86-35	Челябинск +7 (351) 277-89-65
Йошкар-Ола +7 (8362) 38-66-61	Нижнекамск +7 (8555) 24-47-85	Смоленск +7 (4812) 51-55-32	Череповец +7 (8202) 49-07-18
Казань +7 (843) 207-19-05			Ярославль +7 (4852) 67-02-35

сайт: \ cZzf.pro-solution.ru | эл. почта: \ fz@pro-solution.ru |
телефон: 8 800 511 88 70



The specifications contained herein are subject to change without notice and any user of said specifications should verify from the manufacturer that the specifications are currently in effect. Otherwise, the manufacturer assumes no responsibility for the use of specifications which may have been changed and are no longer in effect.

The quality system covering the design, manufacture and testing of our products is certified to International Standard ISO 9001.

