



Турбинные расходомеры высокого давления серии ННР

Технические характеристики



По вопросам продаж и поддержки обращайтесь:

Архангельск +7 (8182) 45-71-35
Астана +7 (7172) 69-68-15
Астрахань +7 (8512) 99-46-80
Барнаул +7 (3852) 37-96-76
Белгород +7 (4722) 20-58-80
Брянск +7 (4832) 32-17-25
Владивосток +7 (4232) 49-26-85
Владимир +7 (4922) 49-51-33
Волгоград +7 (8442) 45-94-42
Воронеж +7 (4732) 12-26-70
Екатеринбург +7 (343) 302-14-75
Иваново +7 (4932) 70-02-95
Ижевск +7 (3412) 20-90-75
Иркутск +7 (3952) 56-24-09
Йошкар-Ола +7 (8362) 38-66-61
Казань +7 (843) 207-19-05

Калининград +7 (4012) 72-21-36
Калуга +7 (4842) 33-35-03
Кемерово +7 (3842) 21-56-70
Киров +7 (8332) 20-58-70
Краснодар +7 (861) 238-86-59
Красноярск +7 (391) 989-82-67
Курск +7 (4712) 23-80-45
Липецк +7 (4742) 20-01-75
Магнитогорск +7 (3519) 51-02-81
Москва +7 (499) 404-24-72
Мурманск +7 (8152) 65-52-70
Наб.Челны +7 (8552) 91-01-32
Ниж.Новгород +7 (831) 200-34-65
Нижневартковск +7 (3466) 48-22-23
Нижнекамск +7 (8555) 24-47-85

Новороссийск +7 (8617) 30-82-64
Новосибирск +7 (383) 235-95-48
Омск +7 (381) 299-16-70
Орел +7 (4862) 22-23-86
Оренбург +7 (3532) 48-64-35
Пенза +7 (8412) 23-52-98
Первоуральск +7 (3439) 26-01-18
Пермь +7 (342) 233-81-65
Ростов-на-Дону +7 (863) 309-14-65
Рязань +7 (4912) 77-61-95
Самара +7 (846) 219-28-25
Санкт-Петербург +7 (812) 660-57-09
Саранск +7 (8342) 22-95-16
Саратов +7 (845) 239-86-35
Смоленск +7 (4812) 51-55-32

Сочи +7 (862) 279-22-65
Ставрополь +7 (8652) 57-76-63
Сургут +7 (3462) 77-96-35
Сызрань +7 (8464) 33-50-64
Сыктывкар +7 (8212) 28-83-02
Тверь +7 (4822) 39-50-56
Томск +7 (3822) 48-95-05
Тула +7 (4872) 44-05-30
Тюмень +7 (3452) 56-94-75
Ульяновск +7 (8422) 42-51-95
Уфа +7 (347) 258-82-65
Хабаровск +7 (421) 292-95-69
Чебоксары +7 (8352) 28-50-89
Челябинск +7 (351) 277-89-65
Череповец +7 (8202) 49-07-18
Ярославль +7 (4852) 67-02-35

TURBINE FLOWMETERS BY
HOFFER

Perfecting Measurement™



HHP Series
Turbine Flowmeters

Product Bulletin HO-HHP-100I

TECHNICAL DATA SHEET

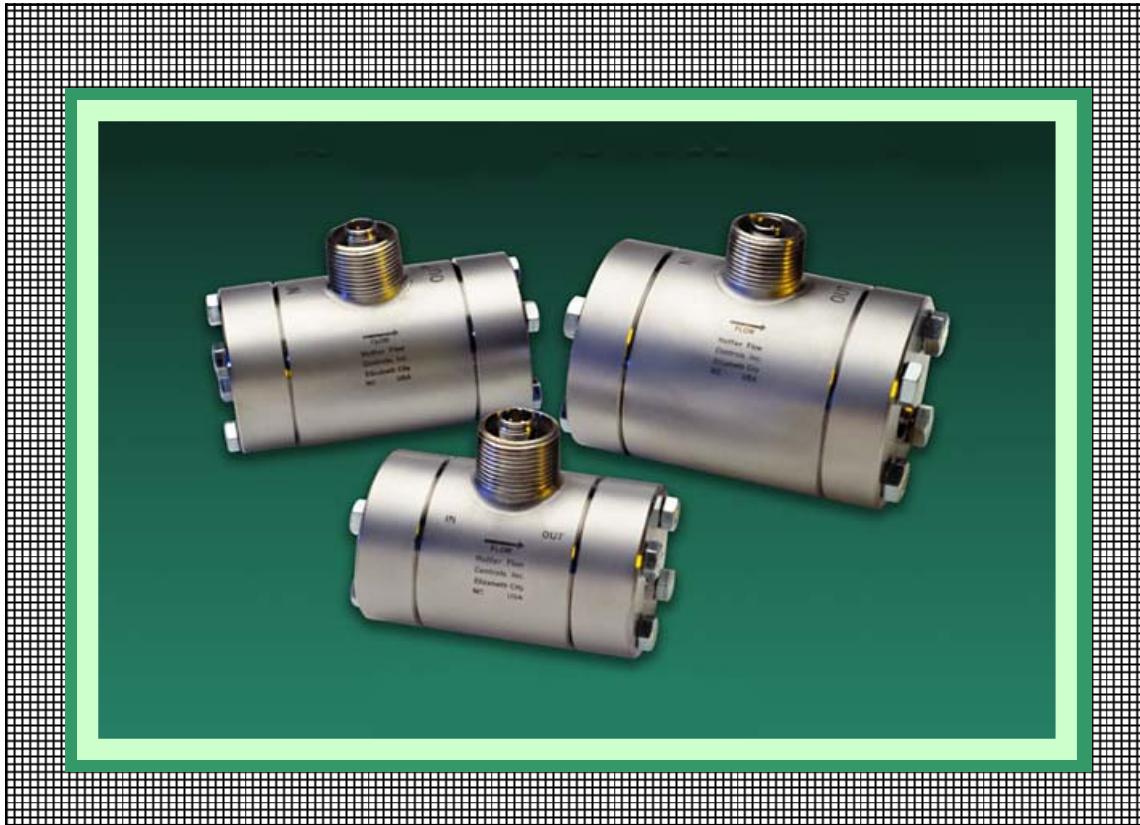

HHP SERIES
Hoffer High Pressure Turbine Flowmeters

OUTSTANDING FEATURES

- Low cost.
- Outstanding accuracy.
- Provides wide flow ranges (10:1 to 100:1 turndown ranges available).
- One piece 316/316L S/S Construction for most pressures.
- For use with unique Hoffer high pressure 316/316L or carbon steel mating flange kits, supplied complete with SAE J429 Grade 8 high yield strength bolts and "O" rings.
- Operate over a wide range of temperatures.
- Sizes 1/4" through 2". Pressure ratings of 3,000, 6,000, 8,000, and 10,000 psi available for most sizes.
- Larger sizes and pressures available upon request. Contact factory.

HOFFER HIGH PRESSURE TURBINE SERIES FOR LIQUID (SIZES 1/4" THRU 2" WITH FOUR PRESSURE RATINGS OF 3,000 PSIG, 6,000 PSIG, 8,000 PSIG AND 10,000 PSIG)

SPECIFICATIONS

Overrange: 150% of maximum flow (intermittently).

Linearity: $\pm 0.5\%$ of reading ($\pm 0.25\%$ typical) over tabulated linear flow range.

Repeatability: $\pm 0.1\%$ ($\pm 0.05\%$ typical) over tabulated repeatable range.

Pressure Drop Characteristics: 4 to 5 PSI at maximum linear flow rate at one CSTK.

Available Turn Down Range: 10:1 to 100:1.

Available Temperature Range: -40°F to $+350^{\circ}\text{F}$ Standard. Temperature ratings are dependent on o-ring materials used. Consult factory for extended temperature range applications.

Bearing Styles: Ceramic hybrid ball bearings, sleeve bearings in tungsten carbide and hard carbon composite are available.

Materials: 316 stainless steel standard. Consult with applications group for corrosive applications. Broad material list available.

LIQUID SIZE SELECTOR CHART FOR HHP SERIES TURBINE FLOWMETERS

FLOWMETER SIZE Diameter (Inches)	MAGNETIC PICKUP COIL				MODULATED PICKUP COIL			
	Linear Range (US GPM)	Linear Range (LPM)	Repeatable Range (US GPM)	Repeatable Range (LPM)	Linear Range (US GPM)	Linear Range (LPM)	Repeatable Range (US GPM)	Repeatable Range (LPM)
HHP 1/2 X 1/4*	.35-3.5	1.3-13.2	.25-4.5	.95-17	.35-3.5	1.3-13.2	.0625-4.5	.24-17
HHP 1/2 X 3/8*	.75-7.5	2.8-28.4	.3-9	1.1-34	.75-7.5	2.8-28.4	.075-9	.28-34
HHP 1/2 X 1/2	1.25-9.5	4.7-36	.6-12	2.3-45	1.25-9.5	4.7-36	.12-12	.45-45
HHP 3/4 X 5/8	1.75-16	6.6-60.6	.9-20	3.4-75.7	1.75-16	6.6-60.6	.2-20	.75-75.7
HHP 3/4 X 3/4	2.5-29	9.5-110	1.5-35	5.7-132.5	2.5-29	9.5-110	.35-35	1.3-132.5
HHP 1 X 1	4-60	15-227	2-75	7.6-284	4-60	15-227	.75-75	2.8-284
HHP 1 1/4 X 1 1/4	6-93	23-352	3-115	11.4-435	6-93	23-352	1.15-115	4.35-435
HHP 1 1/2 X 1 1/2	8-130	30.3-492	5-175	19-662	8-130	30.3-492	1.75-175	6.6-662
HHP 2 X 2	15-225	56.8-852	11-275	42-1041	15-225	56.8-852	2.75-275	10.4-1041

NOTE: Performance enhancement techniques are routinely applied to produce larger linear and usable flow ranges. Consult with the applications group at Hoffer with your requirements.

* The linear flow ranges on 1/4" and 3/8" may be derated depending on bearing selection. Consult applications group for additional information.

GAS APPLICATIONS FOR HHP SERIES TURBINE FLOWMETERS Consult factory for gas applications/sizing.



TYPICAL HHP SERIES APPLICATIONS:

- SUBSEA
- HYDRAULICS

OTHER HIGH PRESSURE METERS OFFERED BY HOFFER:

- WING NUT SERIES
- INSERTION AH SERIES

DIMENSIONAL INFORMATION

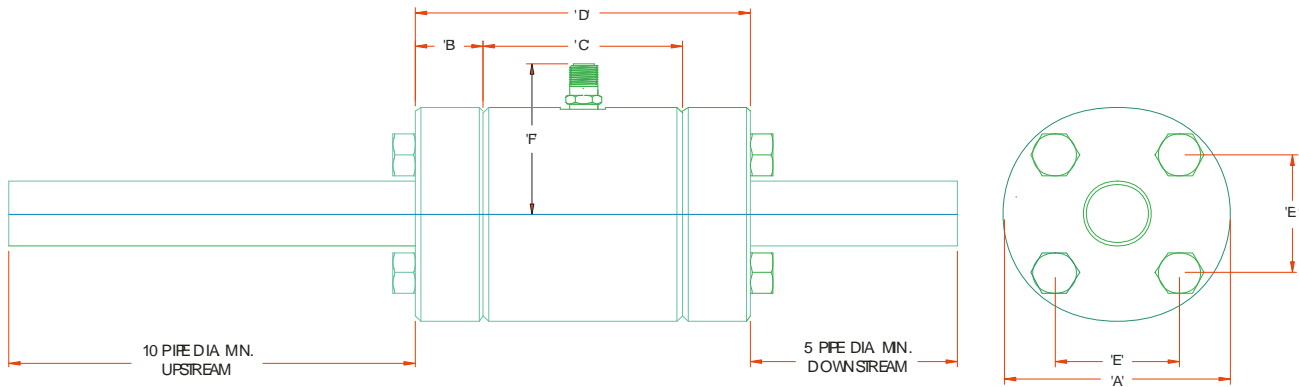

Dimensional and Bolt Information for the HHP Series									
FLOWMETER SIZE	'A'	'B'	'C'	'D'	'E'	'F'	O'RING	BOLTS	BOLT TORQUE
									FT-LB +/-12%
HHP 1/2 X 1/4, 1/2 X 3/8, 1/2 X 1/2									
3000	3.00	1.00	3.50	5.50	1.437	2.65	-212	3/8-16 X 1.75	23 FT-LB
6000	3.00	1.00	3.50	5.50	1.437	2.65	-212	3/8-16 X 1.75	23 FT-LB
8000	4.25	1.75	3.50	7.00	2.25	3.28	-212	1/2-13 X 2.75	59 FT-LB
10000	4.25	1.75	3.50	7.00	2.25	3.28	-212	1/2-13 X 2.75	59 FT-LB
HHP 3/4 X 5/8 AND 3/4 X 3/4									
3000	3.00	1.00	3.50	5.50	1.438	2.65	-214	3/8-16 x 1.75	23 FT-LB
6000	3.20	1.00	3.50	5.50	1.75	2.75	-214	3/8-16 x 1.75	23 FT-LB
8000	4.00	1.38	3.50	6.25	2.12	3.15	-214	1/2-13 x 2.50	59 FT-LB
10000	5.00	1.75	3.50	7.00	2.50	3.65	-214	5/8-11 x 3.00	119 FT-LB
HHP 1 X 1									
3000	4.00	1.00	3.50	5.50	2.00	3.15	-219	1/2-13 x 2.00	59 FT-LB
6000	4.00	1.00	3.50	5.50	2.00	3.15	-219	1/2-13 x 2.00	59 FT-LB
8000	4.50	1.38	3.50	6.25	2.30	3.40	-219	5/8-11 x 2.50	119 FT-LB
10000	5.20	2.00	3.50	7.50	2.75	3.75	-219	3/4-10 x 3.50	214 FT-LB
HHP 1-1/4 X 1-1/4									
3000	4.00	1.00	3.87	5.87	2.00	3.15	-222	1/2-13 X 2.00	59 FT-LB
6000	5.20	1.25	3.87	6.37	2.75	3.75	-222	5/8-11 X 2.50	119 FT-LB
8000	5.20	1.62	3.87	7.11	2.65	3.75	-222	5/8-11 X 2.75	119 FT-LB
10000	6.50	2.25	3.87	8.37	3.50	4.40	-222	7/8-9 X 4	347 FT-LB
HHP 1-1/2 X 1-1/2									
3000	5.00	1.25	4.38	6.88	2.75	3.65	-223	5/8-11 X 2.50	119 FT-LB
6000	5.00	1.50	4.38	7.38	2.75	3.65	-223	5/8-11 X 2.50	119 FT-LB
8000	6.20	1.88	4.38	8.14	3.40	4.25	-223	3/4-10 X 3.50	214 FT-LB
HHP 2 X 2									
3000	5.00	1.25	4.75	7.25	2.75	3.65	-226	5/8-11 X 2.25	119 FT-LB
6000	6.20	1.75	4.75	8.25	3.50	4.25	-226	3/4-10 X 3.00	214 FT-LB

HHP TURBINE FLOWMETER MODEL NUMBERING SYSTEM

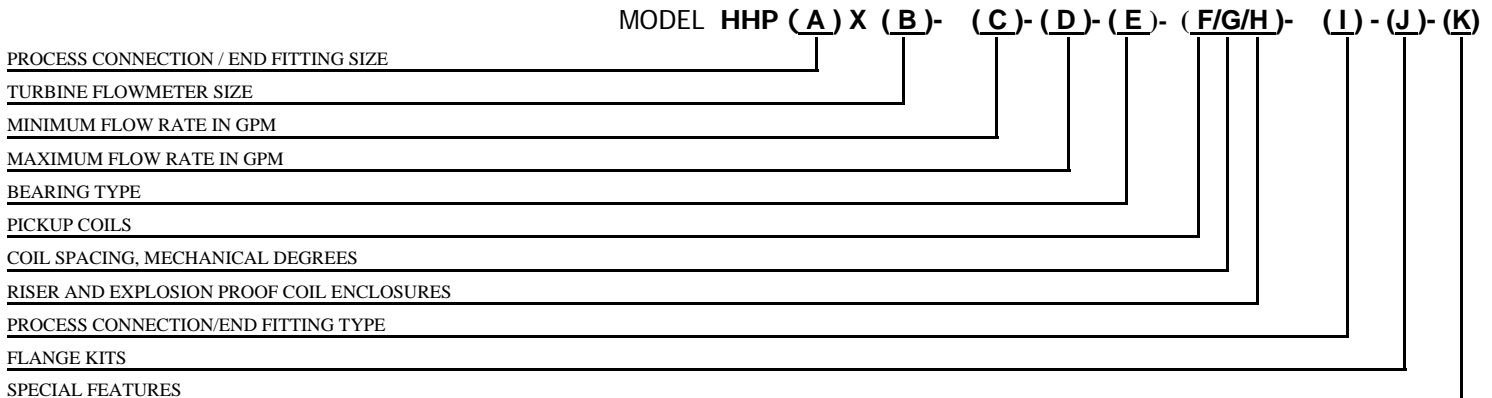

NOTE: WHEN ORDERING, THE CUSTOMER'S PROCESS PIPE SCHEDULE AND SIZE NEEDS TO BE INDICATED.

PROCESS CONNECTION/END FITTING SIZE & TURBINE FLOWMETER SIZE

HHP 1/2 X 1/4 HHP 1/2 X 3/8 HHP 1/2 X 1/2 HHP 3/4 X 5/8 HHP 3/4 X 3/4 HHP 1 X 1	THE FLANGES FOR THESE SIZES WITH 3000#, 6000#, 8000#, & 10,000# PRESSURES ARE PART OF A ONE PIECE HOUSING CONSTRUCTION .
HHP 1 1/2 X 1 1/2*	*THE FLANGES FOR THE 1 1/2" SIZE WITH 3000#, 6000#, & 8000# PRESSURES ARE PART OF A ONE PIECE HOUSING CONSTRUCTION. THE FLANGES FOR THE 1 1/2" SIZE WITH 10,000# PRESSURE ARE WELDED TO THE HOUSING BODY.
HHP 2 X 2**	**THE FLANGES FOR THE 2" SIZE WITH 3000# & 6000# PRESSURES ARE PART OF A ONE PIECE HOUSING CONSTRUCTION. THE FLANGES FOR THE 2" SIZE WITH 8000# & 10,000# PRESSURES ARE WELDED TO THE HOUSING BODY.

MINIMUM FLOW AND MAXIMUM FLOW RATE IN GPM

MODEL HHP()X()-(C)-(D)-(/ /)-()-()-()

NOTE: FOR EXTENDED RANGES REFER TO SIZE SELECTOR CHARTS.

TURBINE SIZE	(C) MINIMUM FLOW	TO	(D) MAXIMUM FLOW
1/4"	.35 GPM		3.5 GPM
3/8"	.75 GPM		7.5 GPM
1/2"	1.25 GPM		9.5 GPM
5/8"	1.75 GPM		16 GPM
3/4"	2.5 GPM		29 GPM
1"	4 GPM		60 GPM
1 1/4"	6 GPM		93 GPM
1 1/2"	8 GPM		130 GPM
2"	15 GPM		225 GPM

BEARING TYPE

MODEL HHP()X()-()-()-(E)-(/ /)-()-()-()

OPTION (E)

1/4" THRU 5/8" TURBINE SIZES

- (BP) CERAMIC HYBRID BALL BEARING, SELF LUBRICATING
- (C) HARD CARBON COMPOSITE SLEEVE BEARING
- (T) TUNGSTEN CARBIDE SLEEVE BEARING

3/4" THRU 1" TURBINE SIZES

- (BP) CERAMIC HYBRID BALL BEARING, SELF LUBRICATING
- (C) HARD CARBON COMPOSITE SLEEVE BEARING
- (T) TUNGSTEN CARBIDE SLEEVE BEARING

1 1/4" THRU 1 1/2" TURBINE SIZES

- (CB) CERAMIC HYBRID BALL BEARING, SELF LUBRICATING
- (C) HARD CARBON COMPOSITE SLEEVE BEARING
- (T) TUNGSTEN CARBIDE SLEEVE BEARING

2" TURBINE SIZE

- (CB) CERAMIC HYBRID BALL BEARING, SELF LUBRICATING
- (C) HARD CARBON COMPOSITE SLEEVE BEARING
- (T) TUNGSTEN CARBIDE SLEEVE BEARING

OPTIONAL ACCESSORIES



HIT-4U
Rate Indicator / Totalizer
(Refer to the HIT-4U Technical Data Sheet)



Nova-Flow Computer
(Refer to Technical Data Sheet NF-102)

PICKUP COILS

MODEL **HHP**()X()-()-()-()-(**F / L**)-()-()-()

OPTION (F)

(1M)	ONE MAG COIL	(1RPMXXX)	ONE REDI-PULSE MAG COIL (SEE REDI-PULSE AND I.S. REDI-PULSE DATA SHEETS TO COMPLETE REDI-PULSE PART NUMBERS)
(2M)	TWO MAG COILS	(2RPMXXX)	TWO REDI-PULSE MAG COILS
(1MC3PA)	ONE RF COIL	(1RPRXXX)	ONE REDI-PULSE RF COIL
(2MC3PA)	TWO RF COILS	(2RPRXXX)	TWO REDI-PULSE RF COILS
(1MC2PAHT)	ONE HIGH TEMP 6" PIGTAIL RF COIL	(1DMXXXX)	ONE REDI-PULSE INTRINSICALLY SAFE MAG COIL
(2MC2PAHT)	TWO HIGH TEMP 6" PIGTAIL RF COILS	(2DMXXXX)	TWO REDI-PULSE INTRINSICALLY SAFE MAG COILS
(1HTM)	HIGH TEMP MAG COIL	(1DRXXXX)	ONE REDI-PULSE INTRINSICALLY SAFE RF COIL
(2HTM)	TWO HIGH TEMP MAG COILS	(2DRXXXX)	TWO REDI-PULSE INTRINSICALLY SAFE RF COILS
(1ISM)	ONE INTRINSICALLY SAFE MAG COIL	(-P*)	PIGTAIL OR FLYING LEADS, ADD -P AND THE *LENGTH OF LEADS AFTER ANY COIL EXCEPT THE HIGH TEMPERATURE COILS
(2ISM)	TWO INTRINSICALLY SAFE MAG COILS		
(1ISM-ATEX)	ONE ISM ATEX COIL		
(2ISM-ATEX)	TWO ISM ATEX COILS		

COIL SPACING, MECHANICAL DEGREES

MODEL **HHP**()X()-()-()-()-(**/ G /**)-()-()-()

NOTE (**G**): 90 DEGREE ELECTRICAL COIL SPACING FOR TWO COILS REQUIRE THE FOLLOWING MECHANICAL SPACING:

TURBINE SIZE	FORWARD MECH. DEGREES	REVERSE DEGREES	MECH. DEGREES	COIL SPARE DEGREES
1/4"	ZERO	Sizes 1/4" through 1", consult factory for spacing.		
3/8"	ZERO			
1/2"	ZERO			
5/8"	ZERO			
3/4"	ZERO			
1"	ZERO			
1 1/4"	ZERO	75 or 105	250	
1 1/2"	ZERO	75 or 105	250	
2"	ZERO	101.25	250	

RISER AND EXPLOSION PROOF COIL ENCLOSURES

MODEL **HHP**()X()-()-()-()-(**/ / H**)-()-()-()

OPTION (H)

(X)	1" MNPT Riser, welded to body, required for all type of enclosures.
(X-ATEX)	3/4" Male NPT Coil Riser-ATEX Exd Compliant.
(XE2)	1" MNPT Riser with E2 enclosure. (See chart)*
(X-ATEX)E2	3/4" MNPT Riser with E2 enclosure. (See chart)*
(X8S)	8" Long S/S 1" MNPT riser. (For fluid temperatures below -40°F (-40°C) or above +140°F +60°C).
(X8S-ATEX)	8" Long S/S 3/4" MNPT riser. (For fluid temperatures below -40°F (-40°C) or above +140°F +60°C).

*E2 EXPLOSION-PROOF/FLAME-PROOF ENCLOSURE WITH 3/4" FNPT MOUNT AND 3/4" CABLE ENTRY RATINGS:	
FM:	CLASS I, DIV. 1, GR. ABCD, CLASS II/III, DIV. 1, GR. EFG, TYPE 4X
CSA:	CLASS I, DIV. 1, GR. ABCD, CLASS II, DIV. 1, GR. EFG, CLASS III, TYPE 4X EX D IIC, CLASS I, ZONE 1, IP 66
ATEX:	EX II 2GD Ex d tD IIC, IP66/68
IEC:	EX D IIC IP68

PROCESS CONNECTION/END FITTING TYPE

MODEL **HHP**()X()-()-()-()-(**/ / /**)-(**1**)-()-()

OPTION (1)

NOTE: THE FLANGES FOR THE FOLLOWING SIZES ARE PART OF THE ONE PIECE HOUSING BODY AND ARE 316 S/S.

1/2-HHP3,000-SS	1-HHP3,000-SS	1 1/2-HHP3,000-SS
1/2-HHP6,000-SS	1-HHP6,000-SS	1 1/2-HHP6,000-SS
1/2-HHP8,000-SS	1-HHP8,000-SS	1 1/2-HHP8,000-SS
1/2-HHP10,000-SS	1-HHP10,000-SS	
3/4-HHP3,000-SS	1 1/4-HHP3,000-SS	2-HHP3,000-SS
3/4-HHP6,000-SS	1 1/4-HHP6,000-SS	2-HHP6,000-SS
3/4-HHP8,000-SS	1 1/4-HHP8,000-SS	
3/4-HHP10,000-SS	1 1/4-HHP10,000-SS	

NOTE: THE FLANGES FOR THE FOLLOWING SIZES ARE WELDED TO THE HOUSING BODY AND CAN BE CARBON STEEL OR 316 S/S.

1 1/2-HHP10,000-SS	2-HHP8,000-SS 2-HHP10,000-SS
1 1/2-HHP3,000-CS 1 1/2-HHP6,000-CS 1 1/2-HHP8,000-CS 1 1/2-HHP-10,000-CS	2-HHP3,000-CS 2-HHP6,000-CS 2-HHP8,000-CS 2-HHP10,000-CS

FLANGE KITS

MODEL HHP()X()-()-()-()-(/ /)-()-(J)-()

OPTION (J)

NOTE: ALL SIZES MUST USE THE HOFFER FLANGE KITS WHICH ARE UNIQUE TO THE HOUSING BODY. ALL SIZES CAN BE EITHER CARBON STEEL OR 316 S/S.

EACH KIT CONSISTS OF:

2 EA. SOCKET WELD FLANGES , 2 EA. VITON ‘O’ RINGS, 1 SET BOLTS AND WASHERS (REFER TO DIMENSIONAL INFORMATION)

OPTION (J)	
1/2"-FK3000-SS 1/2"-FK3000-CS	3,000# MATING FLANGE HHP KIT 316 S/S 3,000# MATING FLANGE HHP KIT C/S
1/2"-FK6000-SS 1/2"-FK6000-CS	6,000# MATING FLANGE HHP KIT 316 S/S 6,000# MATING FLANGE HHP KIT C/S
1/2"-FK8000-SS 1/2"-FK8000-CS	8,000# MATING FLANGE HHP KIT 316 S/S 8,000# MATING FLANGE HHP KIT C/S
1/2"-FK10,000-SS 1/2"-FK10,000-CS	10,000# MATING FLANGE HHP KIT 316 S/S 10,000# MATING FLANGE HHP KIT C/S
3/4"-FK3000-SS 3/4"-FK3000-CS	3,000# MATING FLANGE HHP KIT 316 S/S 3,000# MATING FLANGE HHP KIT C/S
3/4"-FK6000-SS 3/4"-FK6000-CS	6,000# MATING FLANGE HHP KIT 316 S/S 6,000# MATING FLANGE HHP KIT C/S
3/4"-FK8000-SS 3/4"-FK8000-CS	8,000# MATING FLANGE HHP KIT 316 S/S 8,000# MATING FLANGE HHP KIT C/S
3/4"-FK10,000-SS 3/4"-FK10,000-CS	10,000# MATING FLANGE HHP KIT 316 S/S 10,000# MATING FLANGE HHP KIT C/S
1"-FK3000-SS 1"-FK3000-CS	3,000# MATING FLANGE HHP KIT 316 S/S 3,000# MATING FLANGE HHP KIT C/S
1"-FK6000-SS 1"-FK6000-CS	6,000# MATING FLANGE HHP KIT 316 S/S 6,000# MATING FLANGE HHP KIT C/S
1"-FK8000-SS 1"-FK8000-CS	8,000# MATING FLANGE HHP KIT 316 S/S 8,000# MATING FLANGE HHP KIT C/S
1"-FK10,000-SS 1"-FK10,000-CS	10,000# MATING FLANGE HHP KIT 316 S/S 10,000# MATING FLANGE HHP KIT C/S
1 1/4"-FK3000-SS 1 1/4"-FK3000-CS	3,000# MATING FLANGE HHP KIT 316 S/S 3,000# MATING FLANGE HHP KIT C/S
1 1/4"-FK6000-SS 1 1/4"-FK6000-CS	6,000# MATING FLANGE HHP KIT 316 S/S 6,000# MATING FLANGE HHP KIT C/S
1 1/4"-FK8000-SS 1 1/4"-FK8000-CS	8,000# MATING FLANGE HHP KIT 316 S/S 8,000# MATING FLANGE HHP KIT C/S
1 1/4"-FK10,000-SS 1 1/4"-FK10,000-CS	10,000# MATING FLANGE HHP KIT 316 S/S 10,000# MATING FLANGE HHP KIT C/S

OPTION (J)	
1 1/2"-FK3000-SS 1 1/2"-FK3000-CS	3,000# MATING FLANGE HHP KIT 316 S/S 3,000# MATING FLANGE HHP KIT C/S
1 1/2"-FK6000-SS 1 1/2"-FK6000-CS	6,000# MATING FLANGE HHP KIT 316 S/S 6,000# MATING FLANGE HHP KIT C/S
1 1/2"-FK8000-SS 1 1/2"-FK8000-CS	8,000# MATING FLANGE HHP KIT 316 S/S 8,000# MATING FLANGE HHP KIT C/S
1 1/2"-FK10,000-SS 1 1/2"-FK10,000-CS	10,000# MATING FLANGE HHP KIT 316 S/S 10,000# MATING FLANGE HHP KIT C/S
2"-FK3000-SS 2"-FK3000-CS	3,000# MATING FLANGE HHP KIT 316 S/S 3,000# MATING FLANGE HHP KIT C/S
2"-FK6000-SS 2"-FK6000-CS	6,000# MATING FLANGE HHP KIT 316 S/S 6,000# MATING FLANGE HHP KIT C/S
2"-FK8000-SS 2"-FK8000-CS	8,000# MATING FLANGE HHP KIT 316 S/S 8,000# MATING FLANGE HHP KIT C/S
2"-FK10,000-SS 2"-FK10,000-CS	10,000# MATING FLANGE HHP KIT 316 S/S 10,000# MATING FLANGE HHP KIT C/S

SPECIAL FEATURES

MODEL HHP()X()-()-()-()-(/ /)-()-()-(K)

OPTIONS (K)

- (CE) CE MARK - REQUIRED FOR EUROPE
- (PED-CE) PED MARK - REQUIRED FOR EUROPE
- (SEP-CE) SOUND ENGINEERING PRACTICE
- (SP) ANY SPECIAL FEATURES THAT ARE NOT COVERED IN THE MODEL NUMBER, USE A WRITTEN DESCRIPTION OF THE -SP
- (X) NO SPECIAL FEATURES



The specifications contained herein are subject to change without notice and any user of said specifications should verify from the manufacturer that the specifications are currently in effect. Otherwise, the manufacturer assumes no responsibility for the use of specifications which may have been changed and are no longer in effect.

The quality system covering the design, manufacture and testing of our products is certified to International Standard ISO 9001.



По вопросам продаж и поддержки обращайтесь:

Архангельск +7 (8182) 45-71-35	Калининград +7 (4012) 72-21-36	Новороссийск +7 (8617) 30-82-64	Сочи +7 (862) 279-22-65
Астана +7 (7172) 69-68-15	Калуга +7 (4842) 33-35-03	Новосибирск +7 (383) 235-95-48	Ставрополь +7 (8652) 57-76-63
Астрахань +7 (8512) 99-46-80	Кемерово +7 (3842) 21-56-70	Омск +7 (381) 299-16-70	Сургут +7 (3462) 77-96-35
Барнаул +7 (3852) 37-96-76	Киров +7 (8332) 20-58-70	Орел +7 (4862) 22-23-86	Сызрань +7 (8464) 33-50-64
Белгород +7 (4722) 20-58-80	Краснодар +7 (861) 238-86-59	Оренбург +7 (3532) 48-64-35	Сыктывкар +7 (8212) 28-83-02
Брянск +7 (4832) 32-17-25	Красноярск +7 (391) 989-82-67	Пенза +7 (8412) 23-52-98	Тверь +7 (4822) 39-50-56
Владивосток +7 (4232) 49-26-85	Курск +7 (4712) 23-80-45	Первоуральск +7 (3439) 26-01-18	Томск +7 (3822) 48-95-05
Владимир +7 (4922) 49-51-33	Липецк +7 (4742) 20-01-75	Пермь +7 (342) 233-81-65	Тула +7 (4872) 44-05-30
Волгоград +7 (8442) 45-94-42	Магнитогорск +7 (3519) 51-02-81	Ростов-на-Дону +7 (863) 309-14-65	Тюмень +7 (3452) 56-94-75
Воронеж +7 (4732) 12-26-70	Москва +7 (499) 404-24-72	Рязань +7 (4912) 77-61-95	Ульяновск +7 (8422) 42-51-95
Екатеринбург +7 (343) 302-14-75	Мурманск +7 (8152) 65-52-70	Самара +7 (846) 219-28-25	Уфа +7 (347) 258-82-65
Иваново +7 (4932) 70-02-95	Наб.Челны +7 (8552) 91-01-32	Санкт-Петербург +7 (812) 660-57-09	Хабаровск +7 (421) 292-95-69
Ижевск +7 (3412) 20-90-75	Ниж.Новгород +7 (831) 200-34-65	Саранск +7 (8342) 22-95-16	Чебоксары +7 (8352) 28-50-89
Иркутск +7 (3952) 56-24-09	Нижневартковск +7 (3466) 48-22-23	Саратов +7 (845) 239-86-35	Челябинск +7 (351) 277-89-65
Йошкар-Ола +7 (8362) 38-66-61	Нижнекамск +7 (8555) 24-47-85	Смоленск +7 (4812) 51-55-32	Череповец +7 (8202) 49-07-18
Казань +7 (843) 207-19-05			Ярославль +7 (4852) 67-02-35

сайт: \ cZyf.pro-solution.ru | эл. почта: \ fz@pro-solution.ru |
телефон: 8 800 511 88 70



The specifications contained herein are subject to change without notice and any user of said specifications should verify from the manufacturer that the specifications are currently in effect. Otherwise, the manufacturer assumes no responsibility for the use of specifications which may have been changed and are no longer in effect.

The quality system covering the design, manufacture and testing of our products is certified to International Standard ISO 9001.

